



ENGINEERING EXCELLENCE

Installation Guide

Two Handle Lavatory Widespread Faucet:

- 3PR200

This product meets the following standards:

- ASME A112.18.1
- ANSI A117.1
- ANSI / NSF 61, SECTION 9
- CUPC / IAPMO LISTED / ADA COMPLIANT
- CONTAINS NO MORE THAN 0.25% WEIGHTED AVERAGE LEAD CONTENT

Thank you for purchasing this Pioneer quality product.

Tools Required



Plumbers Putty

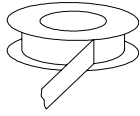

Sealant Tape

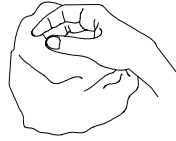

Rags

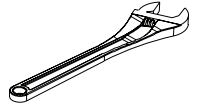

Adjustable-
Wrench

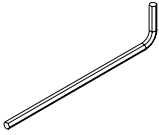

3/32" Allen
Wrench

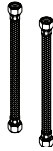

Flex Hose

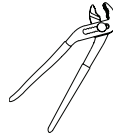

Wrench

Prior to Installation

- Observe all local plumbing and building codes before you begin installation.
- Carefully shut off both hot and cold water supplies from under the sink.
- Plug the sink drain with a soft cloth to prevent intrusion of debris or the loss of any faucet parts.
- For replacement installations, carefully remove the existing faucet and clean the entire surface of the sink mounting holes.
- Pioneer reserves the right to make changes in the design of faucets without notice as specified in the pricebook.

Faucet Installation

1. Place the spout escutcheon (B) underneath of the spout(A). Ensure the gasket (C) is placed underside of the escutcheon (B). Slide the spout (A) through center mounting hole. Slide the mounting bracket (D) through spout shank from underside of center mounting hole.
2. Thread and tighten the spout mounting nut (E). Do not overtighten.

1

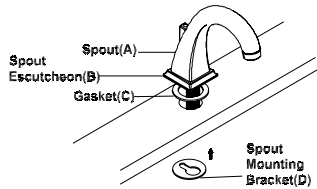

2

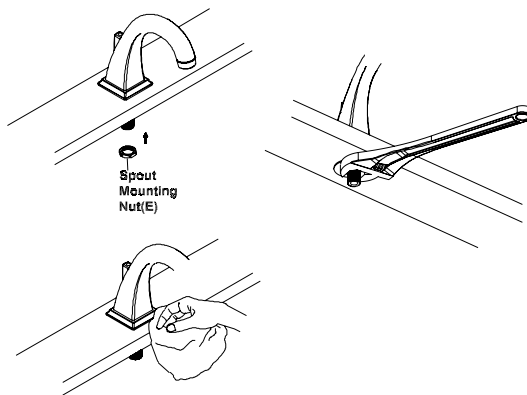

Faucet Installation

3. The hot and cold side valves are marked with 'HOT' and 'COLD' on the valve. Thread the bottom locknut(K), steel washer(J), and rubber washer(I) on the cold side valve. Insert the cold side valve through the sink hole from underneath of the sink. Make sure the valve outlet faces toward the spout(A). Slide the upper rubber washer (I), steel washer(J) and then Thread the upper locknut(K).
4. Ensure that the valve is 1-1/2" above the mounting surface.
5. Thread the handle locknut (H) as far it threads on the valve.
6. Place the Escutcheon (G) and install the handle(F) on handle locknut(H) with the help of handle tool (L). Install the HOT side valve same as COLD side. Ensure both handles turn in correct direction. Confirm the valve outlet faces toward the spout (A).
7. Tighten the bottom locknut (K) to secure the valve to the mounting surface.

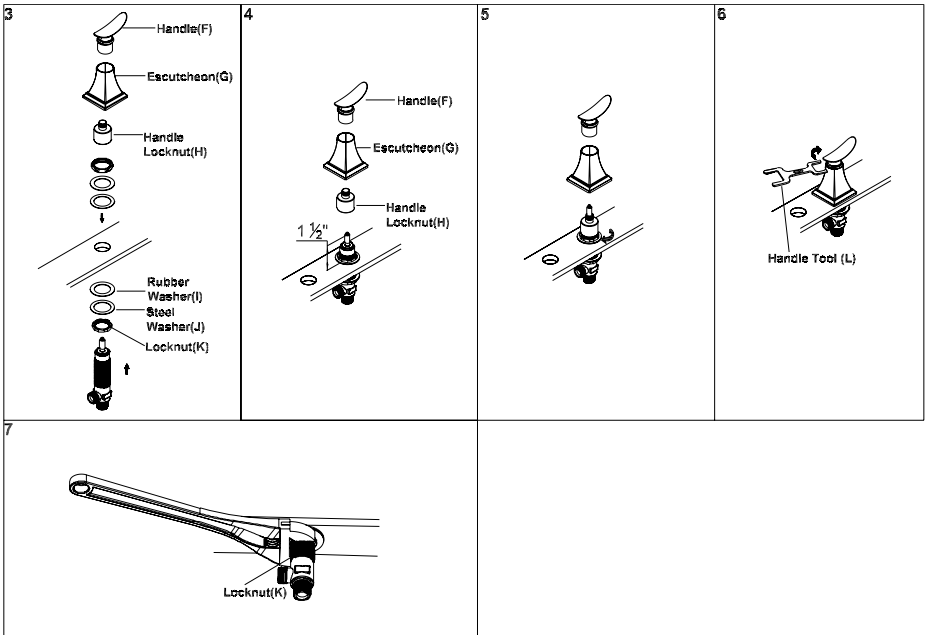

Faucet Installation

8. Remove the 'Y' connector (N). Make sure the washer (M) is in the 'Y' connector (N).
9. Connect the 'Y' connector (N) to the spout shank. Place necessary Teflon tape at the end of the spout if necessary. Do not overtighten.
10. Connect the supply hose (O) to the cold side outlet of the valve body . Place necessary Teflon tape at the outlet of the valve body. Tighten with adjustable wrench. Do not overtighten.
11. Place necessary Teflon tape at the outlet of the valve body. Connect the supply hose (O) to hot side outlet of the valve body.
12. Place necessary Teflon tape at the end of the 'Y' connector. Connect the cold side supply hose same as hot side supply hose to the 'Y' connector (N). Tighten with adjustable wrench. Do not overtighten.
13. Ensure the both side of the supply hoses are securely connected.

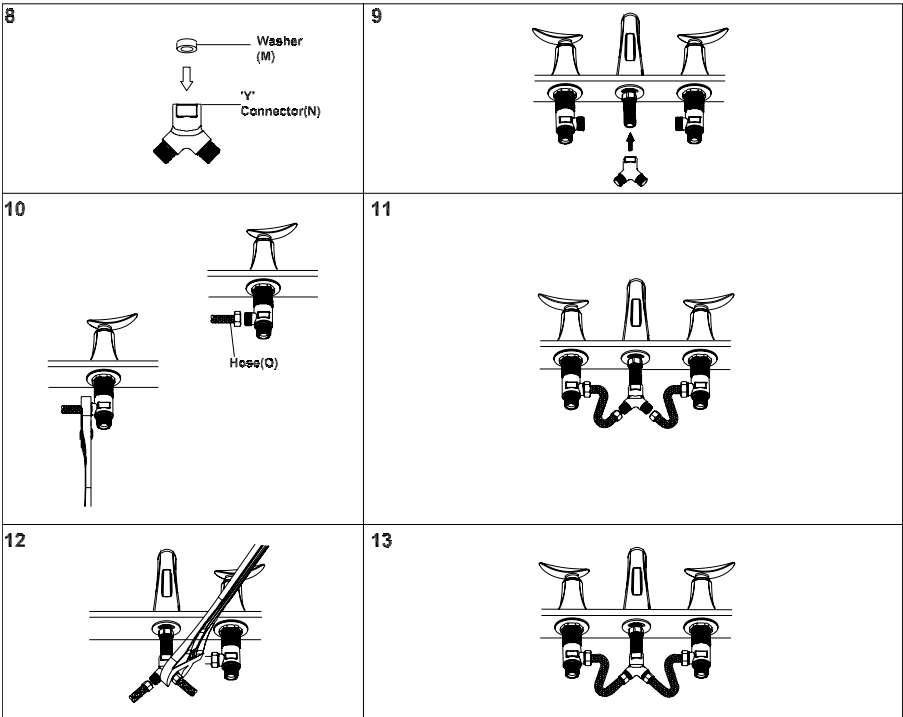

Pop-Up Drain Installation

14. Remove the pop-up stopper (P) and pop-up flange (Q) from the pop-up assembly.
15. Apply adequate amount of plumbers putty underside of pop-up flange (Q). Then insert pop-up drain assembly from underside of the sink and secure the pop-up flange (Q) from the top.
16. Rotate the drain body so that horizontal rod hole faces back of the faucet. Hold the pop-up assembly in place and tighten the locknut (R).
17. Remove the excess putty. Connect the trap (S). (Check manufacturer's instructions for installation).
18. Remove rod nut (T).
19. Ensure the washer (U) is in place (for brass pop-up only). Insert rod (V). Tighten the rod nut (T).
20. Push rod down to open drain. Insert the pop-up stopper (P) carefully. Test if the pop-up stopper (P) is working properly.
21. Connect pop-up bracket to the rod using clip (X). Tighten the thumbscrew (W) to connect pop-up bracket to pop-up lift rod.

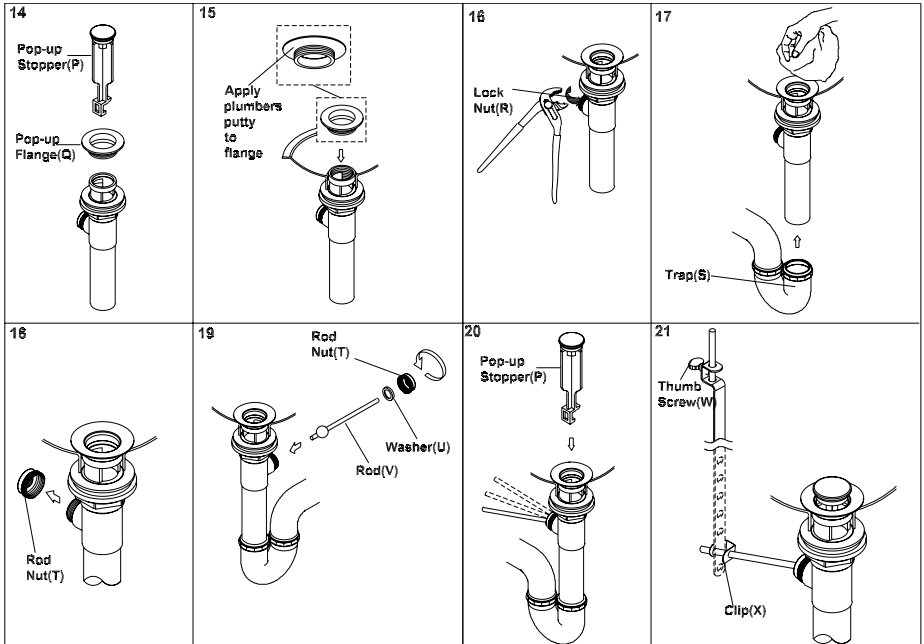

Main Supply Connection

22. Connect the Valves to inlet supply lines (Y). Connect the supply stops (Z) to the inlet supply lines (Y) (left is hot water supply and right is cold water supply). Make sure inlet supply lines (Y) are securely tighten. Do not over tighten. Turn on water. Check for any leaks. Make sure all the connections are secure.
23. Remove aerator (A1). Open the handle.
24. Flush and allow water to run at full flow for at least one minute. Replace aerator (A1).

22

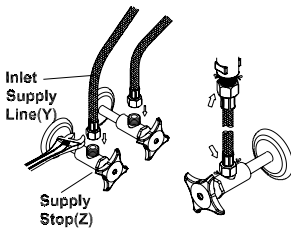

23

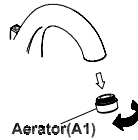

24



For more care information or trouble shooting inquiries about your Pioneer product, please see the contact information on the back page.



ENGINEERING EXCELLENCE

3325 S. Garfield Ave | City of Commerce, CA 90040
Telephone: (800) 338-9468 | (323) 888-8873 | Fax: (323) 888-9515
Hours: M - F, 7:30am to 5:00pm PST